

Atlas Copco



Energy-efficient vacuum solutions

DZS, DZS VSD+ and DZM VSD+
Mono- and multi-claw vacuum solutions

The claw vacuum range

Vacuum variant



DZS 065V



DZS 150V



DZS 300V

Bare shaft variant



DZS 065V



DZS 150V



DZS 300V

Oxygen variant



DZS 065V



DZS 150V



DZS 300V

Pressure variant



DZS 065P



DZS 150P



DZS 300P

DZS VSD+ and DZM VSD+ range



DZS 200 VSD+



DZS 100-400 VSD+



DZM 600-1200 VSD+



Connect and empower

Thousands of applications – central systems in hospitals, CNC routing, pneumatic conveying, milking parlors – share a common need: vacuum. And that is what Atlas Copco provides – safely, reliably, cost-effectively and continuously. Connect with Atlas Copco to get the utility you need to empower your processes and operations, and drive your productivity.



Reliability you can trust

From our manufacturing base in Antwerp, we have delivered tens of thousands of claw pumps. They are working quietly and efficiently in all corners of the world. They are characterized by a low failure rate over a long lifetime, even in the most challenging conditions.



Masters of innovation

The durability of our claw pumps is rooted in our expertise. Our accumulated knowledge and experience results in low-cost, efficient and reliable products.



Fully certified

Our dry claw machines meet the demanding requirements of ISO 9001, ISO 14001 and OHSAS 18001, as verified by Lloyds of London. They are backed up by a market-leading warranty and a service support network across 180 countries. The result? 24/7 assurance that your products and your processes are constantly kept in the best possible working order.

DZS 100-400 VSD+

The DZS 100 VSD+, DZS 200 VSD+ and DZS 400 VSD+ are a range of Class 0 certified dry claw vacuum pumps; single stage, oil-free, air-cooled and with the VSD+ inverter drive technology built-in. The DZS VSD+ series are a range of long life and durable pumps with very low maintenance for rough vacuum applications. These compact machines with small footprint deliver high reliability through a rugged and robust design.

Superior performance. Designed to fit process needs

In terms of performance, the DZS VSD+ series helps achieve increase productivity. This is possible thanks to the integrated VSD+ inverter drive and pressure setpoint control.

As a result, the pump is capable to run with elevated rotor speeds whilst still matching the motor speed to the load coming from the process. The pump can run at its ultimate vacuum level continuously without overheating. Allowing the DZS VSD+ to effortlessly meet a wider range of process demands and vacuum applications.



Pre-wired, plug and play pressure sensor

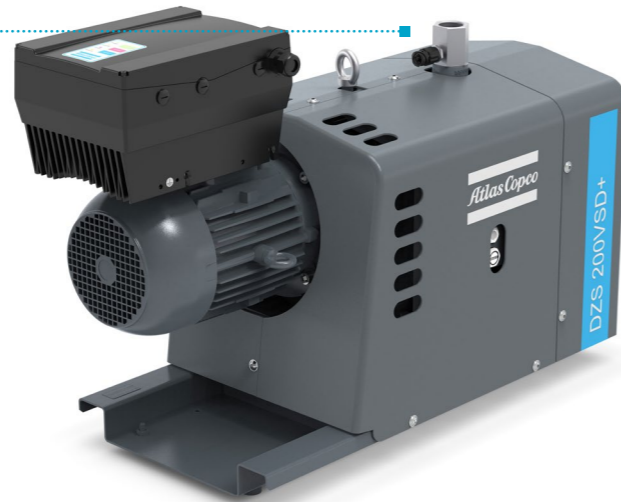

VSD+ drive

Optional connection to temperature sensor

Keypad foil



Centralized intelligence. Decentralized installation

At Atlas Copco, we believe that + is more. The pumps are equipped with a VSD+ drive on the motor, enabling PI-Loop functionality as well as multiple options for remote connectivity, including the in-house developed Atlas Copco VSD+ app. We take a static pump and make it intelligent.

Multiple ways to connect to your DZS VSD+ intelligent pump

- HMI via smartphone or PC:** start/stop/control/commission, local trending and monitoring
- Fieldbus read-out and control:** pressure, speed, temperature, current, RH, power start/stop/control/commission
- HEX@™ Grid LINK:** ability to centralize and control multiple pumps, including regulating pressure, speed and start/stop
- Monitoring:** dashboard, real time, local trending read-out

What if a smartphone could control a vacuum pump?

VSD+ * Introducing the VSD+ app, a unique application for iOS and Android devices – an app that lets you control and monitor a vacuum pump with your smartphone. The VSD+ app allows for ease of commission for your DZS VSD+ vacuum pump by only providing 3 parameters – target pressure, start/stop delay and stop level. Start your pump, connect the VSD+ app via bluetooth, enter the desired parameters and you are set to run your pump.

*The VSD+ app is available both on App Store and Google Play

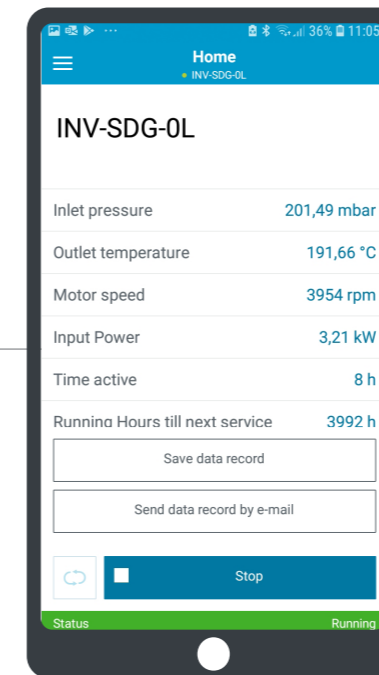

With the VSD+ App you also have live visualization of the actual performance and settings. You can monitor details such as inlet pressure, rotor speed, running hours, service intervals, etc.

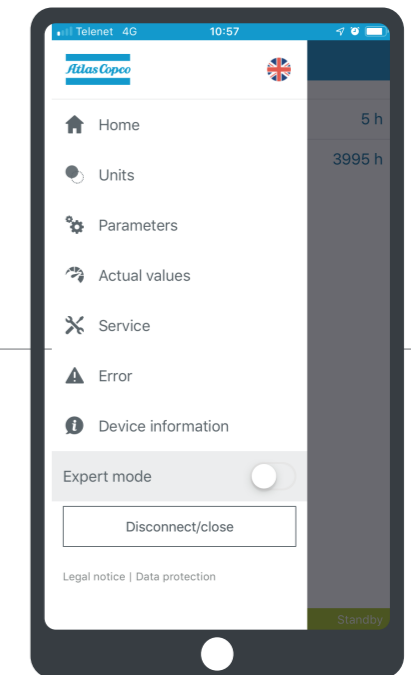

Welcome to the new forefront in vacuum pump control.

Efficient pumps with low life cycle costs

The new range based on Atlas Copco's dry claw technology features an innovative design which creates a new benchmark in the claw pump market. The simplicity, robustness, efficiency and contaminant handling capability of these pumps make them the smart choice for your application. Built to the exacting standards and quality demanded by our customers, the new dry claw pump provides you with a trouble-free and cost-effective solution to meet your needs.



Built to last

Manufactured on the fundamentals of Atlas Copco design, these pumps feature some innovative construction materials and coatings for a lifetime of reliable operation even in harsh conditions.



Easy maintenance

Long life bearings and seals, a separate and isolated pumping element, and the simplest of designs suited for quick access to the pumping chamber make for easy cleaning in the event of product carry-over.



Superior performance

- Extensive product range
- Ultimate vacuum level with continuous operation
- Compact footprint
- Power consumption
- Minimal machine life cycle costs
- Low noise levels

Oxygen variant

The DZS dry claw vacuum pump oxygen variants are specifically designed to pump oxygen-enriched process gases that are greater than 21%. They are ideal for applications that require oxygen-enriched gases such as medical applications, Modified Atmosphere Packaging (MAP) and oxygen generation (VPSA), etc.

For a detailed list of applications, please contact your local Atlas Copco representative.



Designed for a long life of reliable, efficient operation

The dry claw machine boasts some fantastic design features including stainless steel corrosion resistant claws. The renowned Atlas Copco surface coating applied to the pumps' process chambers has proven to be unrivalled in our compressors.

Innovative features



Dry (oil-free) pumping chamber



Efficient motor with variable speed option for complete controllability



Simple maintenance with contact-free internals eliminating wear



Cool running and simple air cooling



Compact design with a small footprint

Built-in corrosion resistance (standard)

- Corrosion resistant stainless steel claws
- Durable coated pumping chamber
- Suitable for many harsh applications

Compact machine with a small footprint

Ideally suited for replacement market, compressor house installations and OEM machinery

Cleverly designed element

- Easily accessible pumping chamber for cleaning without accessing the gearbox and disturbing the timing
- Modular design allows flexibility and efficiency in terms of maintenance and life cycle costs

Variable Speed Drive compatible (VSD)

- Significant energy savings*: potential energy savings of 50% compared to fixed speed machines

**In most applications compared to traditional fixed speed vacuum technologies based on measurement with our Vbox energy audit tool.*

- Improved response to varying demand
- Opportunity to replace multiple machines and centralize pumps in one location to optimize system performance

Upgraded bearings and seals

Based on proven compressor and screw vacuum pump design for long trouble-free life even in the harshest applications

Set-point control option

- Allows you to optimize the energy you use to maintain your process duty point
- The lowest possible flow will be delivered to match your required duty point or speed – nothing is wasted

Multi-claw vacuum system - DZM VSD+

A complete multi-claw vacuum pumping system in a box. A solution perfectly designed to meet your larger process demands with a central vacuum system based on the renowned Atlas Copco philosophy. This vacuum pumping package offers a completely controllable system ranging from 44 to 1,230 m³/h integrated into one cabinet with a simple 'plug & play' concept.



At the heart of this system is the DZS 300V claw pump providing efficiency, robustness and ultimate performance with credentials.

With three sizes of system available, plus the option to expand the central vacuum system with centrally controlled multiple packages, we can offer a complete turn-key solution regardless of your requirements.



Low noise

Atlas Copco prides itself on offering environmentally friendly solutions and noise plays a big part. Our reputation for designing and building noise reducing canopies is renowned in the industry.



Plug & play

This concept of design greatly reduces complexity and installation costs compared to other central systems designs. The package not only consists of the pumps but also comprises the common inlet manifold and an exhaust manifold resulting in two simple pipe connections.

The control system including the Variable Speed Drive and all necessary process transmitters and safety devices are incorporated in a 'cool zone' adding to its simplicity and reliability.

Complete controllability

Atlas Copco's DZM VSD+ multi-vacuum pump controllers allows the DZM package to start/stop and control multiple vacuum pumps simultaneously according to set working pressures. The controller comes with a built-in frequency inverter for the lead pump and the lag pumps are started to lighten the load and lengthen the life of the pump.

Save energy & cut costs

Thanks to smart algorithms, the controller delivers an optimal blend of product performance. It does this by measuring the working pressure and ensuring the collective pumps work together and deliver proportionately.

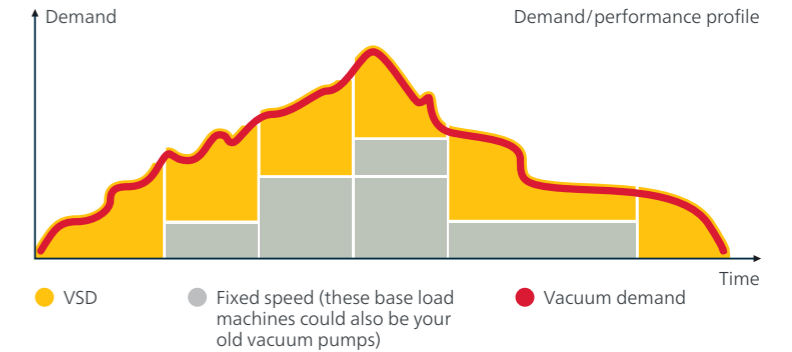

Elektronikon® monitoring system

Elektronikon® is a state-of-the-art monitoring system for your vacuum pumps. It is simple yet comprehensive and leads to energy savings. It can also integrate your plant management system thanks to a remote monitoring option.

Easy to use

- 3.5-inch high-definition color display with clear pictograms, 32 language settings
- Additional LED indicator for service
- Graphical display of key parameters (day, week, month)
- Elektronikon® installed on different vacuum pumps can be monitored in cascade

Comprehensive

- Monitoring: status, running/stopped hours, programmable timers, set point control and other settings
- Safety: Elektronikon® provides warning, fault and shutdown indications
- Service: service operations, remote control (optional)



SMARTLINK: more than just a watchful eye

SMARTLINK is an optional solution for data monitoring: easy to install and customizable. It brings system-relevant data to your smartphone, tablet and PC. Whenever you have access to the internet, you obtain the information you need to respond quickly to changing circumstances. Service calls can be efficiently planned and production losses minimized.



Technical specifications - DZS mono-claw

Vacuum

Type	Nominal displacement		Ultimate vacuum level 'V' version*			Permissible ambient temperature range		Inlet connection size	Outlet connection size	Shaft power	
	m ³ /h	cfm	mbar(a)	"Hg Vac	Torr	°C	°F	BSP	BSP	kW	hp
DZS 065V - 50 Hz	65	38	50	28.3	37.5	0 to 40	32 to 104	G 1 1/4"	G 1 1/4"	1.8	2.0
DZS 065V - 60 Hz	78	47	50	28.3	37.5	0 to 40	32 to 104	G 1 1/4"	G 1 1/4"	2.2	3.0
DZS 150V - 50 Hz	150	88	50	28.3	37.5	0 to 40	32 to 104	G 1 1/4"	G 1 1/4"	3.7	5.0
DZS 150V - 60 Hz	180	104	50	28.3	37.5	0 to 40	32 to 104	G 1 1/4"	G 1 1/4"	3.7	5.0
DZS 300V - 50 Hz	300	176	140	25.8	105	0 to 40	32 to 104	G 2"	G 1 1/4"	6.2	8.3
DZS 300V - 60 Hz	360	208	140	25.8	105	0 to 40	32 to 104	G 2"	G 1 1/4"	7.5	10.0

Pumping speed based on air at 20°C. Tolerance +/-10% | 60Hz Versions supplied with NPT adaptors

*For continuous duty/operation

Low Pressure

Type	Nominal displacement		Ultimate pressure 'P' version		Permissible ambient temperature range		Inlet connection size	Outlet connection size	Shaft power	
	m ³ /h	cfm	bar(g)	psi(g)	°C	°F	BSP	BSP	kW	hp
DZS 065P 50 Hz	65	38	1.8	26	0 to 40	32 to 104	G 1 1/4"	G 1 1/4"	3.7	4.96
DZS 065P 60 Hz	78	46	1.8	26	0 to 40	32 to 104	G 1 1/4"	G 1 1/4"	3.7	3.7
DZS 150P - 50Hz	150	90	2.3	33	0 to 40	32 to 104	G 1 1/4"	G 1 1/4"	11.0	15.0
DZS 150P - 60Hz	180	104	2.3	33	0 to 40	32 to 104	G 1 1/4"	G 1 1/4"	15.0	20.0
DZS 300P - 50Hz	300	180	2.3	33	0 to 40	32 to 104	G 2"	G 1 1/4"	19.0	25.0
DZS 300P - 60Hz	360	208	2.3	33	0 to 40	32 to 104	G 2"	G 1 1/4"	22.0	30.0

Dimensional tolerance +/-10mm/0.4" | Weight tolerance (oil included) +/- 2kg/4.4lbs

Dimensions & weight

Type	Length		Width		Height		Weight	
	mm	in	mm	in	mm	in	kg	lbs
DZS 065V	1022	40.2	394	15.5	545	21.4	120	265
DZS 150V	1036	40.8	394	15.5	545	21.4	160	353
DZS 300V	1113	43.8	500	19.6	692	27.2	258	569
DZS 065P	1052	41.4	416	16.4	673	26.5	160	353
DZS 150P	1159	45.6	416	16.4	673	26.5	204	450
DZS 300P	1372	54.02	502	19.8	804	31.7	315	694

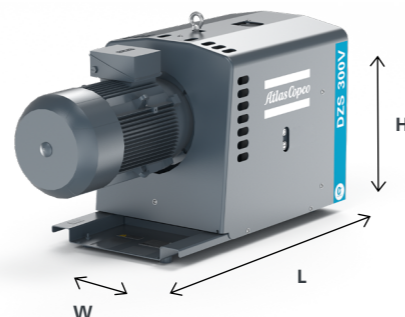

Drawings and Dimensions - DZS mono-claw

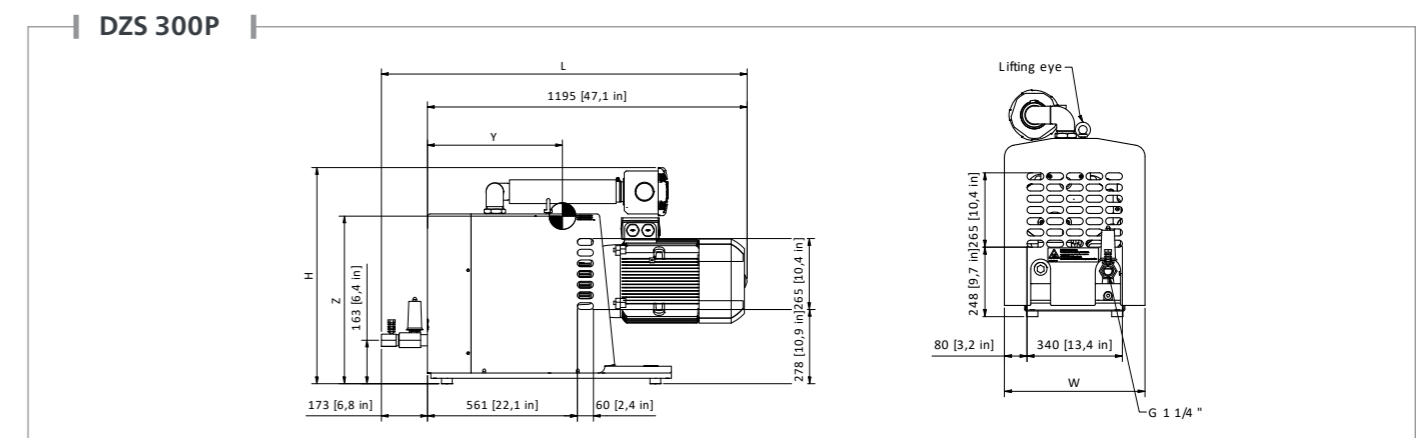
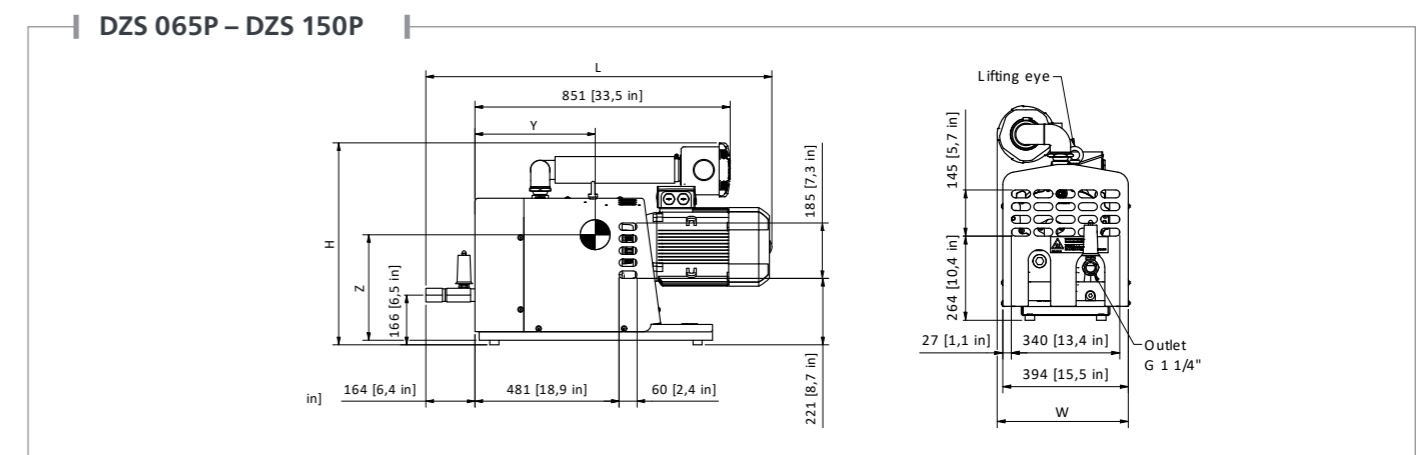
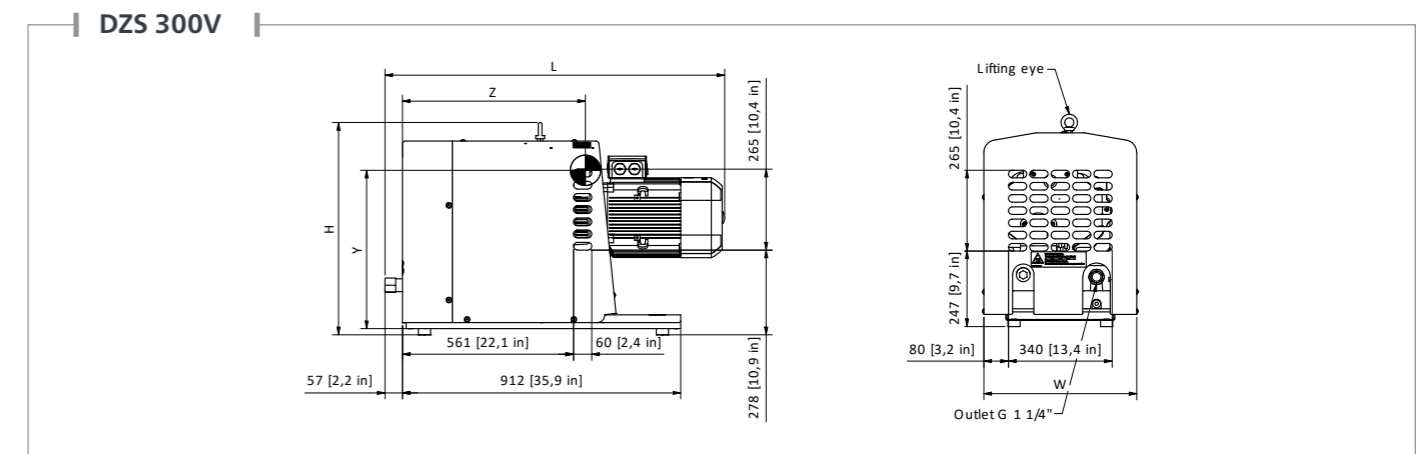
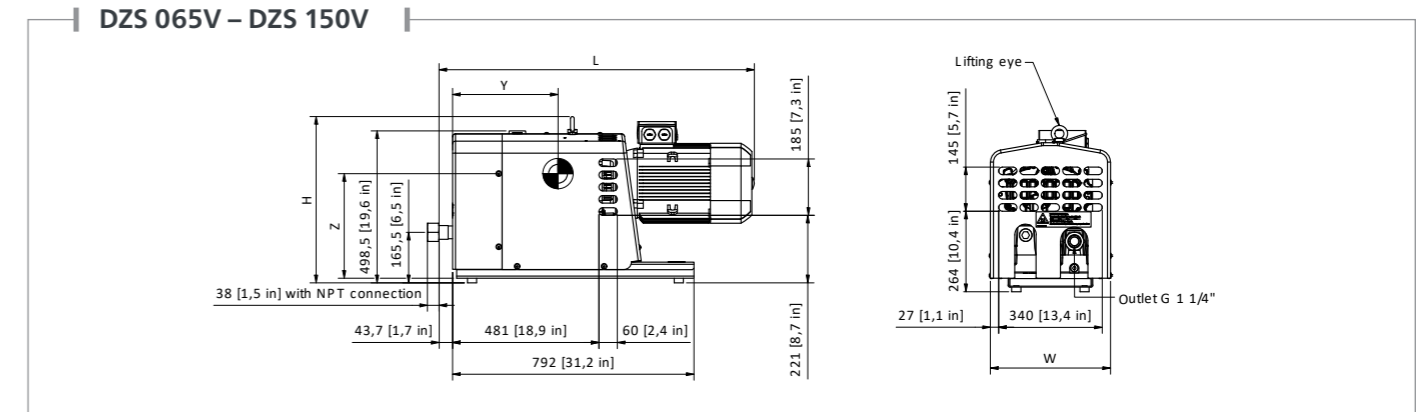

Technical specifications - DZS VSD+

Type	Min pumping speed		Max pumping speed		Ultimate vacuum*		Motor power		
	m ³ /h	cfm	m ³ /h	cfm	mbar	"HgV	kW	hp	
DZS 100 VSD+	4	4	105	62	50	28.4	Overdrive from 200 mbar abs to atmosphere	3	5
DZS 200 VSD+	3	2	189	111	50	28.4		5.5	7
DZS 400 VSD+	44	26	398	234	140	25.4		11	15

*For continuous duty/operation

Dimensions & weight

Type	Length		Width		Height		Weight	
	mm	in	mm	in	mm	in	kg	lbs
DZS 100 VSD+	920	36.2	394	15.5	575.5	22.7	156	344
DZS 200 VSD+	930	36.6	394	15.5	575.5	22.7	170	375
DZS 400 VSD+	1110	43.7	500	19.6	756	29.7	281	619.5

Performance - DZS VSD+

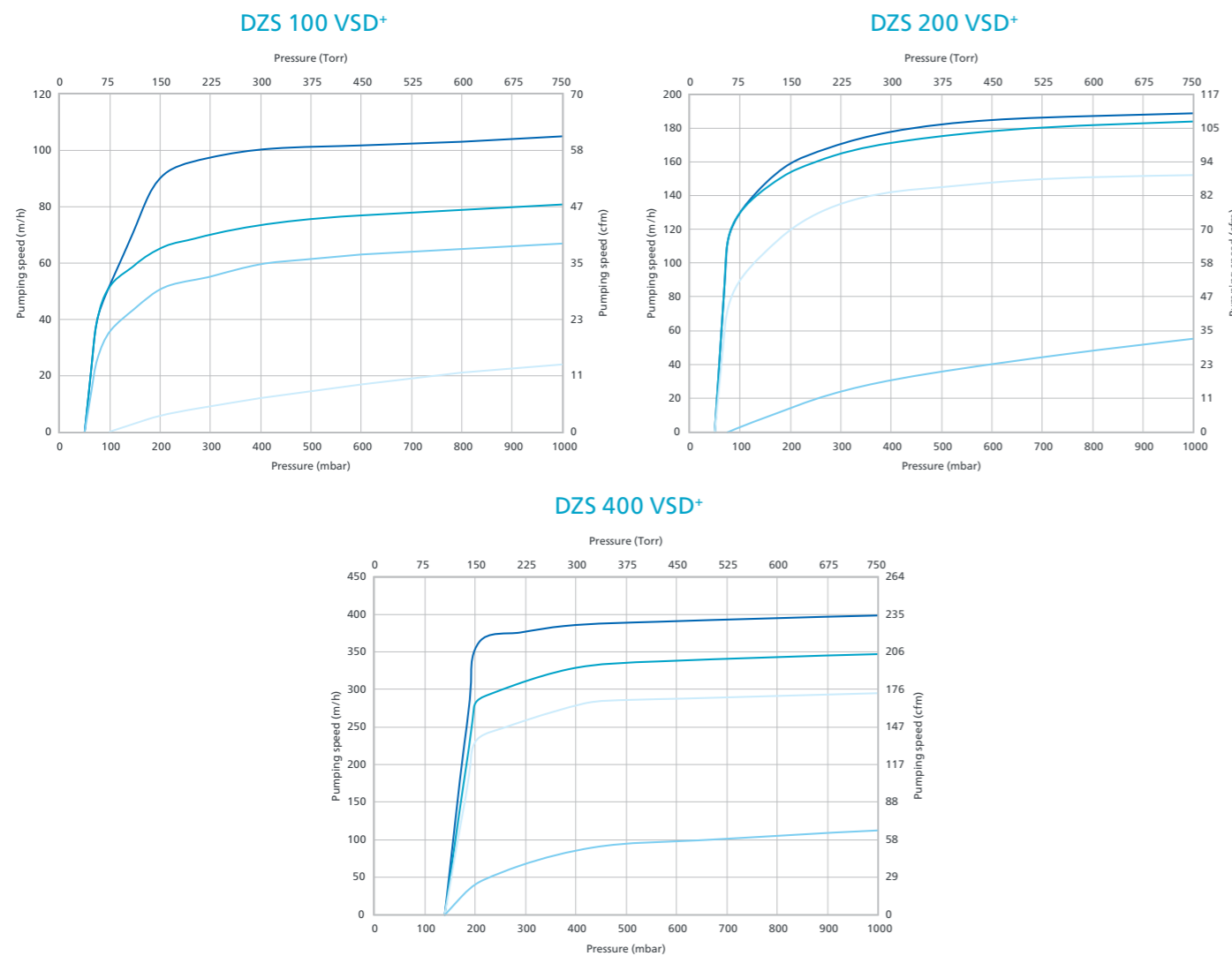

Drawings and Dimensions - DZS VSD+

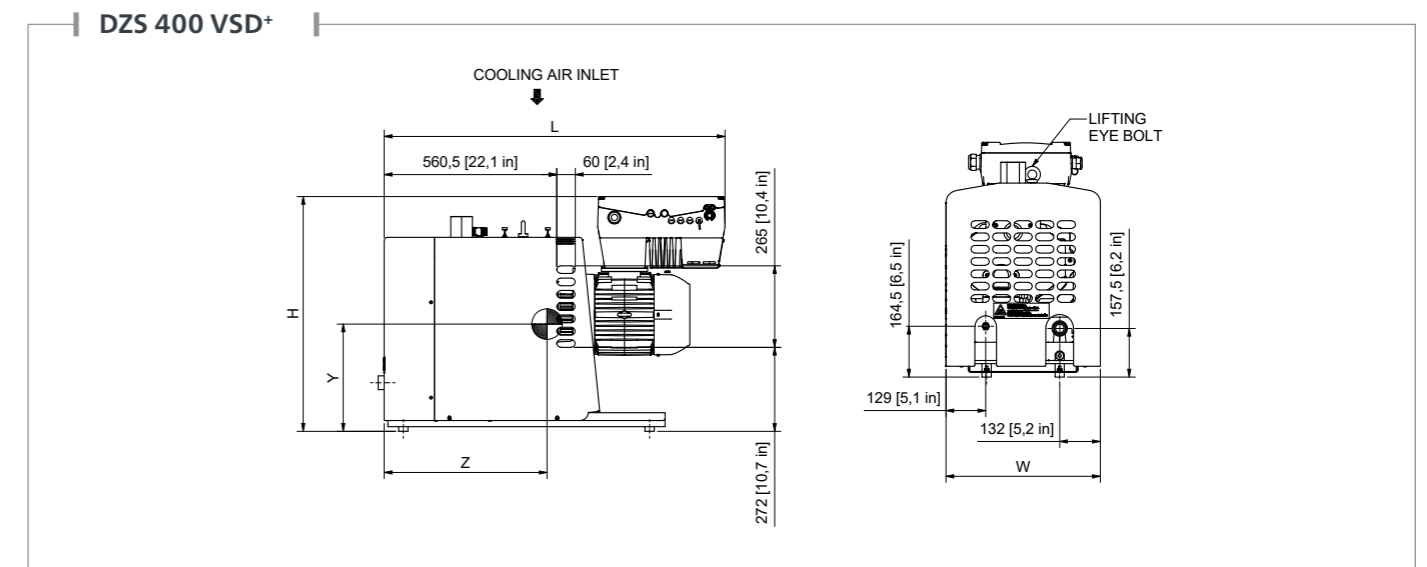
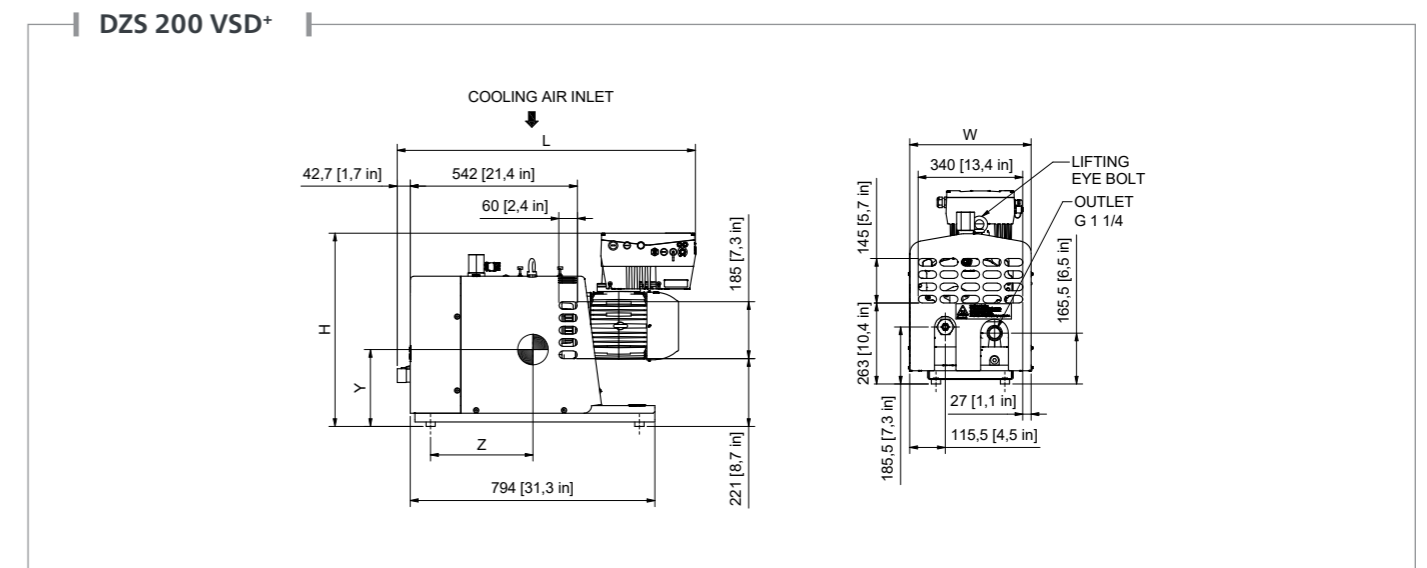
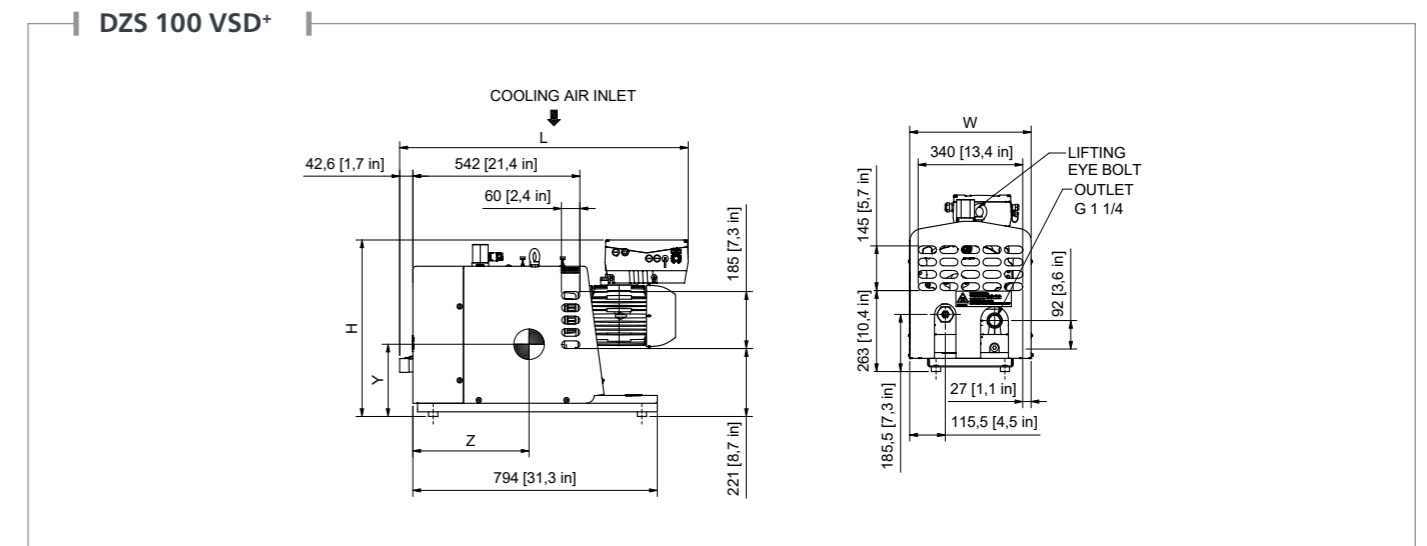

Performance - DZS mono-claw

Vacuum

60Hz 50Hz

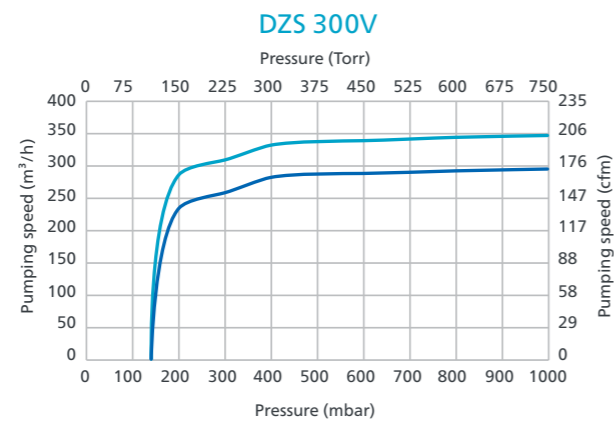
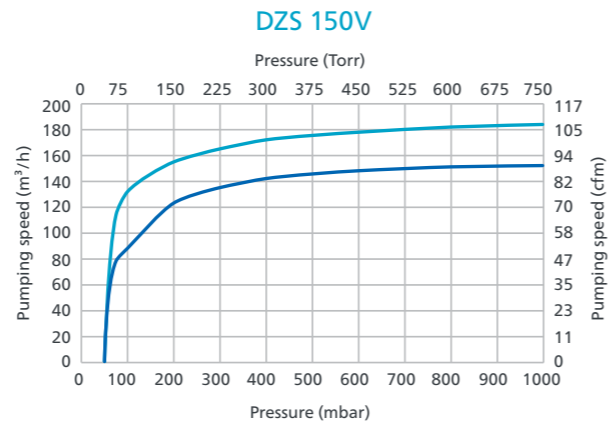
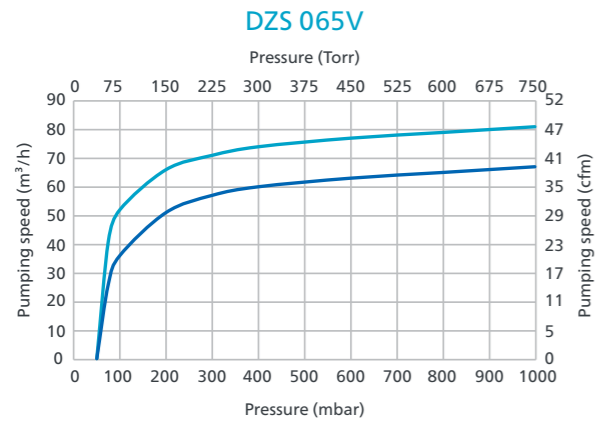

Low Pressure

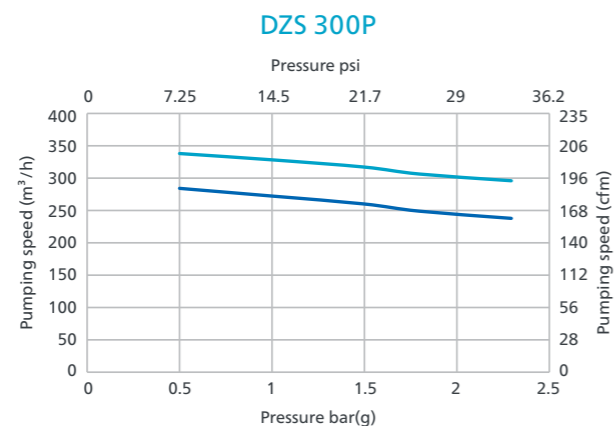
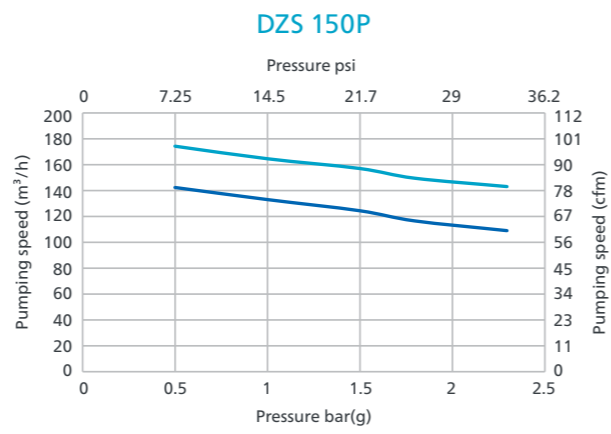
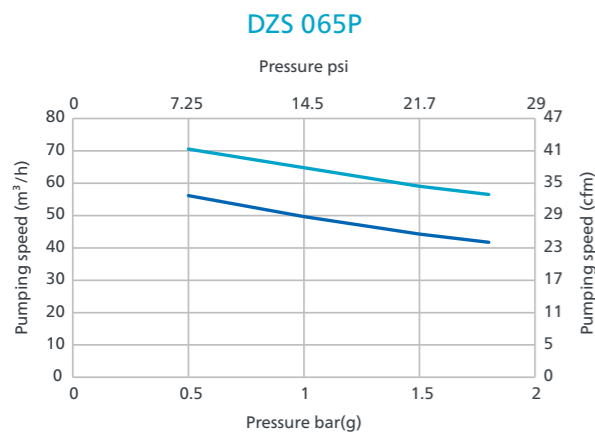

Technical specifications DZM VSD+

Type	Number of integrated pumps	Nominal displacement		Ultimate vacuum Level*			Permissible ambient temperature range		Inlet connection size	Exhaust connection size	Shaft power minimum / maximum	
		m³/h	cfm	mbar(a)	"Hg Vac	Torr	°C	°F	Flange	Flange	kW	hp
DZM 600 VSD+	2 x DZS 300	24 to 604	14 to 356	150	25.8	105	0 to 40	32 to 105	*DN 80	*DN 80	1.2 to 13	1.6 to 17
DZM 900 VSD+	3 x DZS 300	24 to 874	14 to 514	150	25.8	105	0 to 40	32 to 105	*DN 100	*DN 100	1.2 to 19	1.6 to 25
DZM 1200 VSD+	4 x DZS 300	24 to 1143	14 to 673	150	25.8	105	0 to 40	32 to 105	*DN 100	*DN 100	1.2 to 25	1.6 to 33

Figures based on 50Hz operation, 400 V.
 Figures based on lead pump with 20 to 60Hz operation, subsequent pumps operating at 50Hz, 400 V.
 Pumping speed based on air at 20°C. Tolerance +/- 10%.
 Shaft power based on one pump at minimum speed 1200rpm and maximum power achieved when lead pump is at 60Hz operation and lag pumps at 50Hz.
 *US 60Hz Versions supplied with ANSI adaptor flanges
 *For continuous duty/operation

Dimensions & weight

Type	Length		Width		Height		Weight	
	mm	in	mm	in	mm	in	kg	lbs
DZM 600 VSD+	1420	56	905	36	1980	78	800	1764
DZM 900 VSD+	1420	56	1590	62	1980	78	1400	3086
DZM 1200 VSD+	1420	56	1590	62	1980	78	1800	3968

Dimensional tolerances +/- 10mm / 0.4" | Weight tolerances (oil included) +/- 20kg/44lbs





ashair.co.nz
atlascopco.com

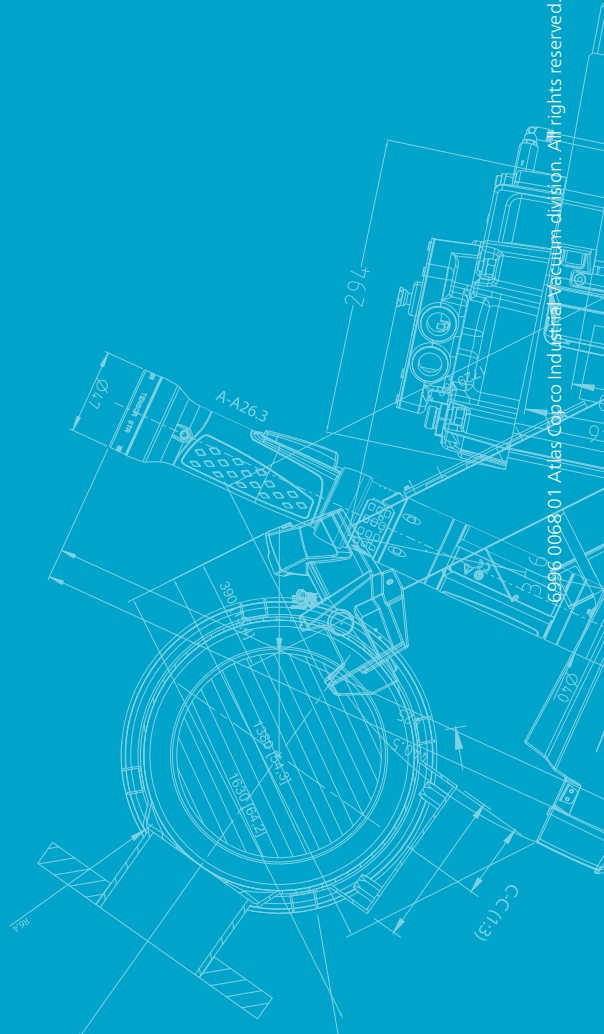

6996 0068 01 Atlas Copco Industrial Vacuum division. All rights reserved. Designs and specifications are subject to change without notice or obligation. Read all safety instructions in the manual before usage.